

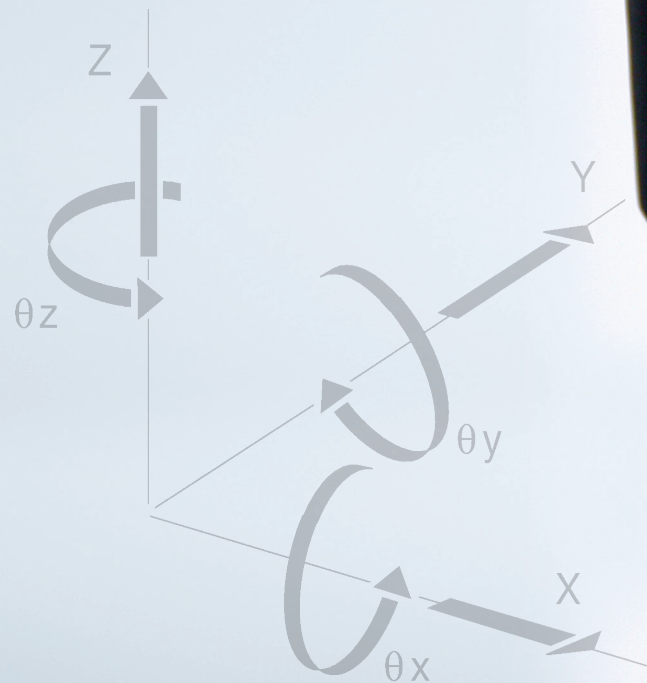

PORTABLE COORDINATE MEASUREMENT SYSTEMS

PRODUCT BROCHURE

VERSION 02



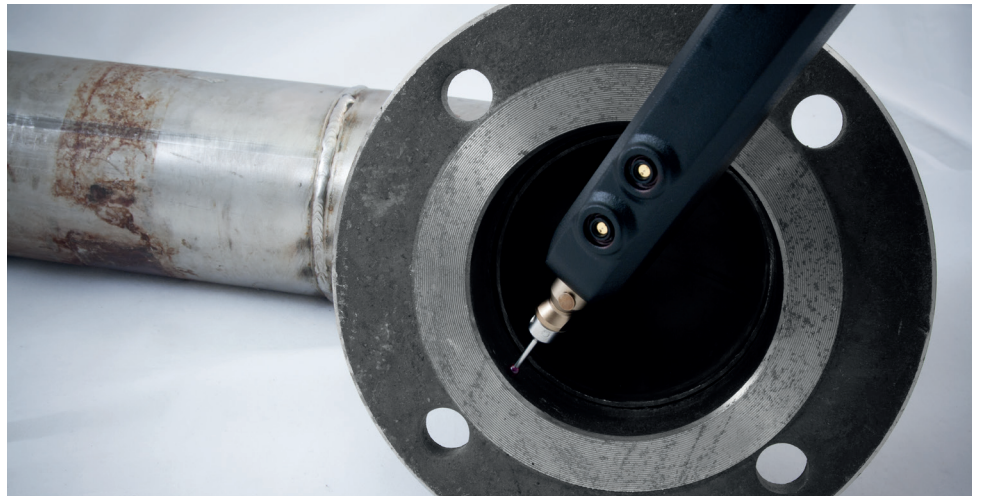

All Metronor technology is built on in-house research and development within electro-optics and photogrammetry – the science of precisely determining the location of items based on images.



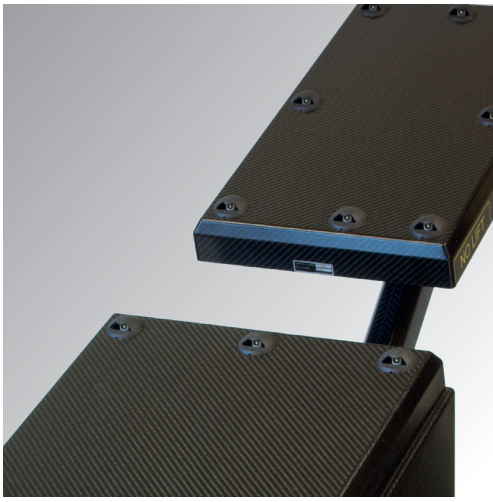

OUR TECHNOLOGY

FOR PORTABLE PRECISION

METRONOR SYSTEMS MEASURE WITH LIGHT

- One or more cameras observe a known pattern of light sources on the handheld probe or scanner, and determine its' position and orientation
- Simple - in principle and in use. The very complex models and mathematics needed to achieve accuracy are handled by the computer - completely transparent to the user

METRONOR SYSTEMS COVER IT ALL

- The cameras only need to see the light sources. The probe tip or the scan area can be hidden from view, making precise deep probing possible and scanning real-life objects simple
- For full surface measurement, choose a Metronor scanner – and fill in with manually probed points in the hard-to-scan areas
- Probe tips of different lengths and shapes can be assembled by the user, making measurement of just about any object easy



ANYTHING FROM A PRECISION FITTING TO A FULL WIND TURBINE BLADE

- Metronor systems can measure just about any industrial object, – in-situ, in-process
- Typical measurement volumes vary from a cubic meter to the size of a large truck



QUICK TO LEARN, EFFICIENT IN USE - FAST RETURN-ON-INVESTMENT

- Simple and intuitive operation with a lightweight handheld probe or scanner, and wizard-like on-screen guidance
- Fast, flexible camera setup
- Market-leading analysis software included - and also compatible with most other analysis software

MINIMAL LIFE-CYCLE COSTS WITH STABLE ACCURACY OVER TIME

- The camera is completely solid state, and the probe has a carbon fiber structure – designed and made to perform well in harsh industrial environments, year after year
- The systems' accuracy is stable over time, and can be verified on-site at any time, with no scheduled recalibration required

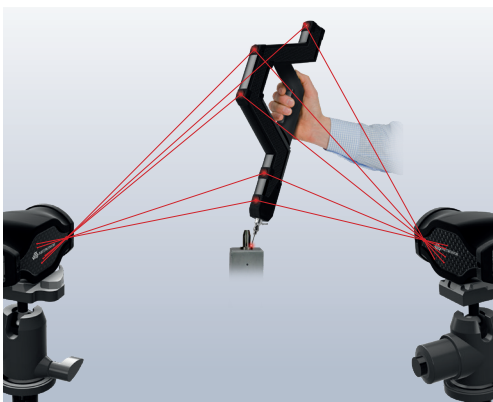

A COMPLETE RANGE OF SYSTEMS ON A COMMON TECHNOLOGY BASIS

LIGHTWEIGHT PROBE

1. Embedded computer for exposure & intensity control and system self-check
2. Infra-red light emitting diodes, active targets
3. Operating button for measurement control
4. Red and green LEDs give instant operator feedback even when far from the computer
5. WiFi link for communication with the system computer
6. Runs on rechargeable, Li-Ion battery. Each charge lasts a full shift, and a second battery is included
7. Advanced carbon-composite shell ensures temperature stability and extreme rigidity and strength while keeping weight down for enhanced operator comfort
8. Robust rubber bumpers help to withstand rough handling
9. Modular design enables easy repair in case of damage



**Note:
Number of probes as well as type and dimensions included vary depending on system type*

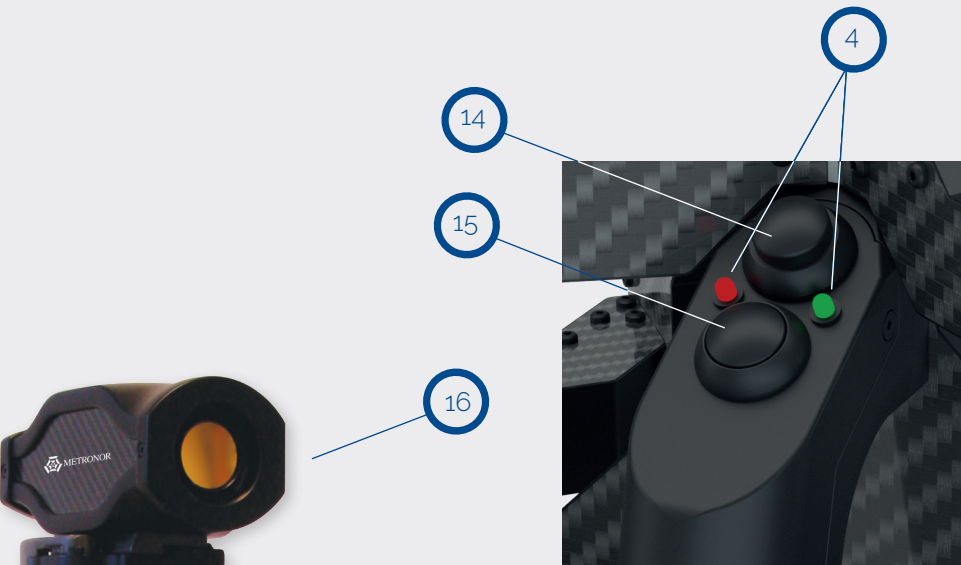

COMPLETE & COMPACT SYSTEMS

10. High precision built-in chuck enables quick probe change without the need for re-calibration
11. User-configurable set of straight and angled probes*
12. Blue-line laser projector
- 13.
14. Menu/reset button
15. On/off operating button for scanning
16. Completely solid-state digital camera with precision optics
17. Compact and lightweight head providing a flexible and stable mounting to the camera
18. Carbon fiber lightweight temperature-stable tripod.
19. Roll away case holds entire system for easy and safe transport of the system**

**Note:

Case type and layout vary depending on system type

METRONOR SYSTEMS

METRONOR PORTABLE SOLUTIONS

Metronor probing and scanning systems offer more flexibility and adaptability than any other portable system. Reconfigure or expand at any time as necessary, securing your initial investment and overcoming new challenges – different measurement volumes, accuracy requirements, probing abilities, or throughput.

Go from probing to scanning whilst staying truly portable, adding surface reverse engineering to an already broad measurement spectrum. Or add probing to your scanning solution, giving it maximum versatility.

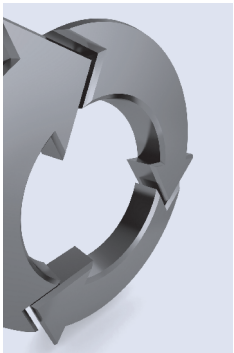
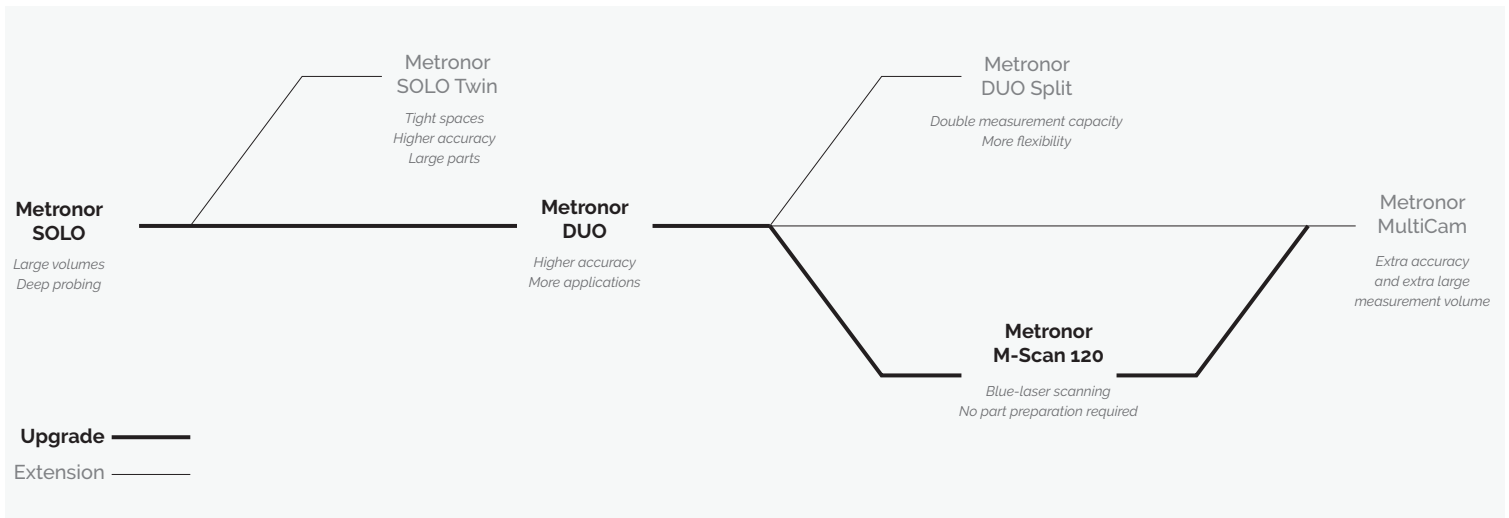

UPGRADES

YOUR INVESTMENT ADAPTS TO NEW REQUIREMENTS

As your company evolves and grows, so do your metrology equipment needs. Experience the freedom of extending and upgrading your existing solution – without making a full new investment. Simply build on what you already have.

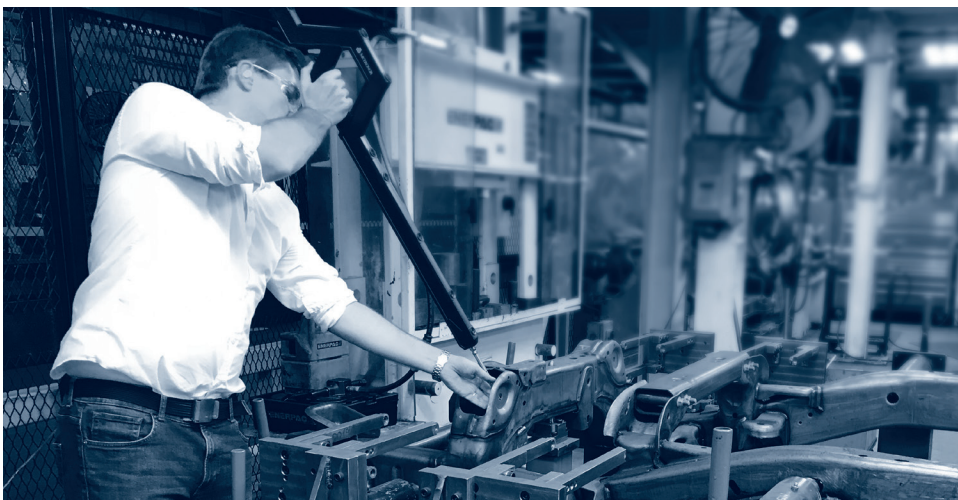

CLOSE-RANGE PROBING SYSTEMS

THE METRONOR SOLUTION TO THE GENERIC ARTICULATED ARM

Metronor One and Two are optimized for close-range measurements of small to medium-size objects up to 2.5 meters. Easier and less tiring to operate than articulated arms, they offer superior probing capabilities and have no need for an anchored mount or pedestal.

The accuracy of the newly released Metronor Two is superior to other close-range portable systems and provides entirely new opportunities. For example, Metronor Two makes audits at suppliers' sites easy also when very high measurement precision is required – a portable system with the accuracy comparable to a stationary CMM.



METRONOR ONE

Metronor One is the ideal portable measurement system for objects of limited size. The lightweight handheld probe works through optics and avoids any mechanical linkages. It is therefore convenient and flexible to operate also for long periods of time, and is reliable and accurate over time.

MAIN BENEFITS:

- True usable measurement volume of 15m³
- Cost-efficient and fast to learn
- Handheld probe without linkages - convenient and reliable
- No need for heavy, stable arm pedestal



METRONOR TWO

Metronor Two is the system to handle tasks of the highest accuracy. Working in the same measurement volume as Metronor One, using a second camera increases the precision of the measurement data. The proven measurement concept of Metronor's traditional two-camera system is used here to triangulate points in closer range, leading to Metronor Two being the system for high-accuracy measurements, when the range of a DUO is not needed.

MAIN BENEFITS:

- Highest accuracy system
- All Metronor One benefits

UPGRADES:

As with the SOLO and DUO line, Metronor One can be upgraded to Metronor Two at any point, staying true to the known flexibility of Metronor's product philosophy.

CAMERA SYSTEMS

METRONOR PORTABLE CMMs

The products in the complete Metronor portfolio are divided into 3 generic groups: close-range probing systems, sticker-free scanning systems and large volume combined systems. Choose the group that fits your company and task the best and grow your system as the needs arise.

COMMON FEATURES:

- Cost-efficient to buy, easy to learn, efficient in use, simple to re-configure – excellent ROI
- Electro-optical principle without mechanical links ensures life-long accuracy - and easy and convenient operation
- Complete measurement solutions including probes, computer, software and transportation case

LARGE VOLUME PROBING SYSTEMS

These industrial measurement solutions are meant for larger objects between 3 and 15 meters and are the cornerstone of Metronor. The choice between either a one-camera or two-camera system gives the user the complete freedom between a larger measurement volume or a higher 3D measurement accuracy.



METRONOR SOLO

Capable of measuring 20 meter sized objects (more with optional extras), SOLO is a flexible and cost-efficient large-volume solution with a wide variety of applications. The system is easy to use and can measure features hidden from view by 450mm plus the probe length.

MAIN BENEFITS:

- Large volume capability
- Extremely easy to learn, very fast to set-up with no warm-up time
- Probing of any detail, including hidden and deeply recessed details
- Excellent for planarity, parallelism, flatness and aligning of shafts



METRONOR DUO

Well established inside major industries such as automotive, aerospace and machining, DUO delivers the highest level of portable CMM accuracy.

By using two cameras, not only is very high accuracy achieved, it also becomes possible to track multiple targets relative to each other, or determining the deformation of structures. DUO systems can also be operated as a SOLO by simply unplugging one of the cameras.

MAIN BENEFITS:

- Highest accuracy with the large volume probing systems
- Widest range of applications, including SwitchMode, deformation monitoring, tracking of objects in all 6 degrees of freedom, and process repeatability testing.

CAMERA SYSTEMS EXTENSIONS

EXTEND YOUR SYSTEM CAPABILITIES

Extend your Metronor system within the same product line/family. System extensions bring you added capability, be it a larger field of view or the ability to multi-task with a metrology system. The component-based approach makes it possible to grow your technology instead of re-investing into completely new solutions.

METRONOR SOLO TWIN

This SOLO extension can be described as a system that uses two cameras to double the field-of-view. This enables the cameras to be placed closer to the measurement object, thereby increasing accuracy, or making it possible to measure in one-setup where several setups would otherwise be needed.

MAIN BENEFITS:

- Full 70° field-of-view
- Efficient in tight and confined spaces
- High accuracy on large objects

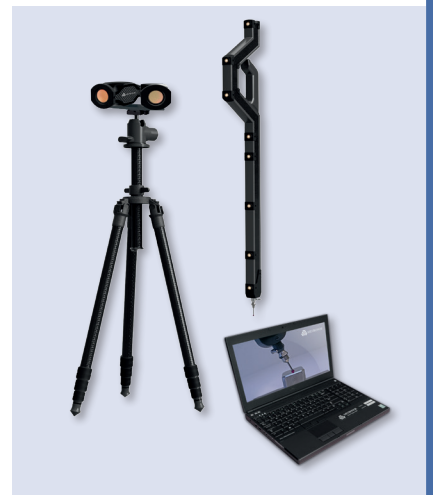

METRONOR DUO SPLIT

This DUO extension turns your DUO into the most flexible measurement solution in the market. DUO Split essentially allows your high-accuracy DUO to be split into two independent SOLOs. For normal tasks, the two SOLOs provide high measurement capacity. When particularly challenging or tight-tolerance inspection is required, DUO operation ensures all requirements are met.

MAIN BENEFITS:

- Most flexible system - use either two independent SOLOs or one DUO
- Best return on investment
- Twice the capacity - or the highest accuracy



METRONOR MULTICAM

Pair several cameras and achieve multiple-camera synchronization, extending your Metronor DUO's photogrammetry also into other directions.

MAIN BENEFITS:

- Extend your measurement area and increase the measurement accuracy
- Take advantage of a static set-up that takes up less floor space than comparable gantry systems
- Expand the system according to project needs: add more cameras or a different type of handheld sensor (e.g. optical scanner)

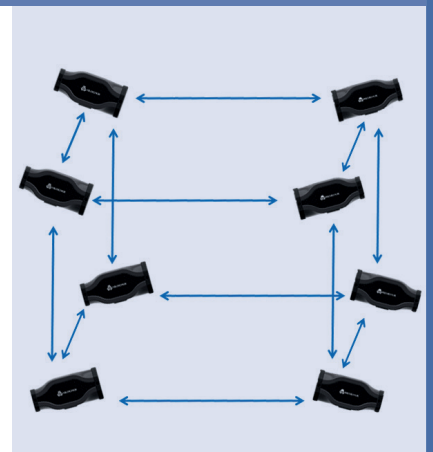



ADD PROBING CAPABILITY

Adding probing capability to your M-Scan 120 system is simple. The Lightpens (Metronor's handheld probes) integrate seamlessly with the system cameras, allowing you to take points and measure hard-to-reach features, expanding the capability of your system and measuring more efficiently.

If there are recessed areas that are difficult to scan, they can be filled in with measurements using the Lightpen, making it the most flexible metrology solution in the market.

MAIN BENEFITS:

- Add probing capability when needed – from the beginning or later on
- Switch between scanning and probing, combining data as needed
- Use deep probing to fill-in areas that cannot be scanned
- Different Lightpen sizes provide a solution adapted to your needs, be those measuring large distances or measuring in tight, confined spaces



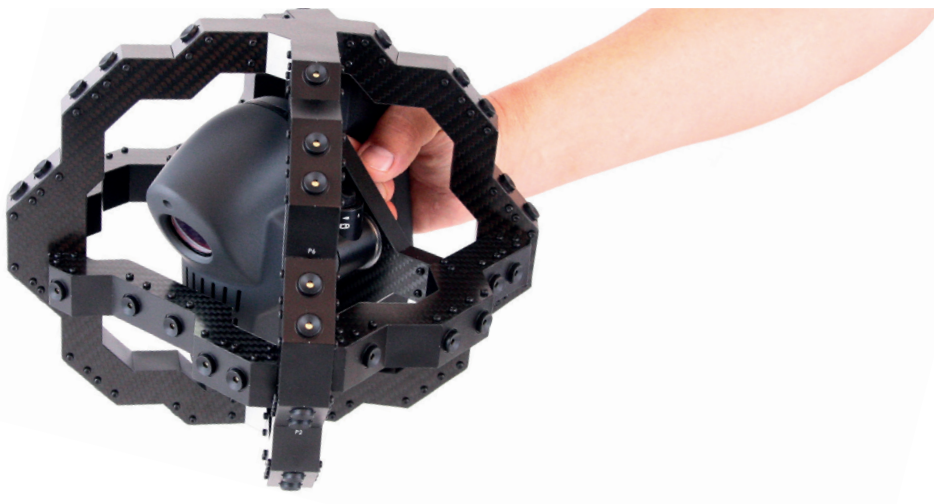

ADD SCANNING CAPABILITY

Scanning capability can easily be added to SOLO and DUO Metronor probing systems. The scanner works together with the system camera or cameras in a similar way to the Lightpen, but returns several hundred thousand points for each measurement.

This makes it a suitable tool for tasks such as part inspection, capturing the precise shape of a clay model or capturing the as-built geometry of a prototype.

MAIN BENEFITS:

- Add scanning capability when needed – from the beginning or later on
- Switch between scanning and probing, combining data as needed
- Capture high-accuracy 3D information in any environment by combining scanning, tracking and probing
- Optimize investment and maximize flexibility

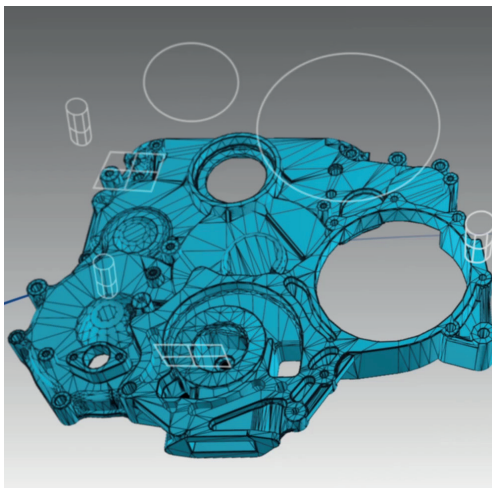
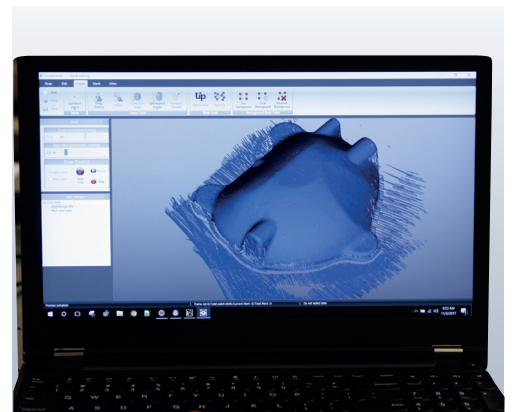
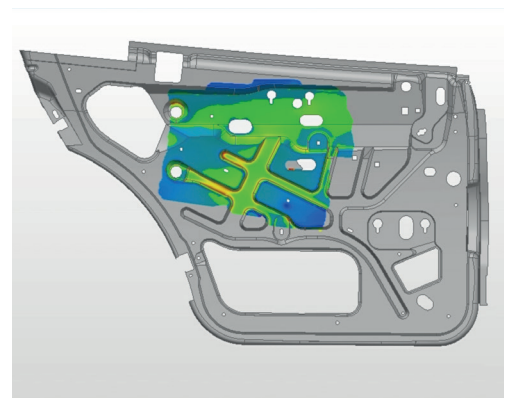

OPTIONS

METRONOR PORTABLE CMMs

All Metronor systems are complete, turn-key solutions. For special applications, additional options are available. Some of these include:



LED APPLICATION KIT (FOR DUO)

Metronor DUO is unique in measuring many points simultaneously. The LED application kit enables a wide range of unique benefits such as vibration stability control, float mode, repeatability studies, deformation and alignment.



LIGHTPENS

Lightpens are available in various sizes, thereby allowing optimal operator ease of use, maximum distances or probing deep and hidden features. The Lightpens are made from stable carbon fiber and have a quick-release chuck for attachment of probes.



PUNCH PROBE

Point stylus with a built-in light-weight automatic center punch. Enables marking features on objects based on measurement data or CAD comparison – once the required point has been found, push the probe against object to leave a punch mark.



CAMERA BATTERY OPTION

The battery option allows any Metronor probing system to operate independent of wall power. It can either be connected to a Metronor One camera, or to a Metronor SOLO or Metronor DUO interface unit – both cable options as well as a wall charger are included.

The battery life is approximately 10 hours per charge if connected to a Metronor One or SOLO, 5 hours for a Metronor DUO.

METRONOR FOR PIPING APPLICATIONS

The combination of TeZetCAD and a Metronor system offers elegant solutions to improve and optimize your piping process.

Measurements are taken on site and in place, capturing the real-time situation. Measure flanges, measure holders, create pipes on-the-fly, optimize the bending process. The Metronor Piping Solution is ideal for when a fast setup, ease of use and high portability are critical.

HERE'S OUR LIST OF
PIPING-RELATED VIDEOS



SHIPYARD SOLUTION

The Shipyard Solution is a type of packaging for either SOLO or SOLO Twin that was developed initially for the use on shipyards, where mobile measurements are taken to another level. Since then this plug-and-play solution has also created a lot of interest for service companies and generally all customers that travel a lot with their Metronor product.

The main difference between the traditional way of packaging and this solution is the pre-plugged in configuration of the system. The transport case – which can also be carried as a backpack – is also the working station, the only thing left to do is to insert the camera cable. In under a minute you can start taking the first measurements, be it for reverse engineering of pipes or for an dimensional check of a finished product.



OTHER SYSTEM CHANGES TO THE REGULAR PACKAGING:

- Exchange of the standard tripod with both magnet and vise to position the camera on walls and beams
- Exchange of standard Lightpen LP89 to the smaller model LP55 for work in smaller, cramped areas
- Additional 2-sided probe tip with a 400mm carbon fiber extension for full reach of hidden features
- Additional camera battery to make the system independent of wall power

Can be used with either SOLO or SOLO Twin, not DUO. Reduced measurement range of 10 meters due to smaller Lightpen model.



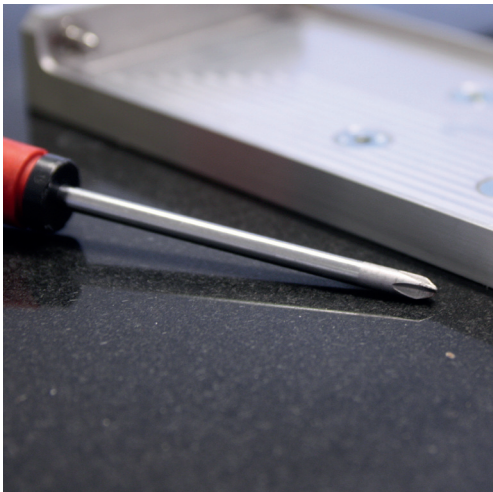

Our support team works hard to ensure a trouble-free life cycle for your portable CMM, offering services ranging from preventative maintenance and online support to efficient repair and calibration services in case of an accident.

CUSTOMER SERVICE

LOCAL PARTNERS: CONTACT YOUR LOCAL METRONOR REPRESENTATIVE

PHONE: YOU CAN CALL OUR SUPPORT TEAM ON +47 66 98 38 00

E-MAIL: SUPPORT@METRONOR.COM



SERVICE & SUPPORT

TECHNICAL ASSISTANCE

The systems' inherent ruggedness and reliability together with our support services ensure that your portable CMM will operate reliably for years to come. We understand that the portable CMM is critical to your operations and represent a considerable investment - and we will work with you to ensure performance you can count on and excellent return on your investment both short-term and long-term.

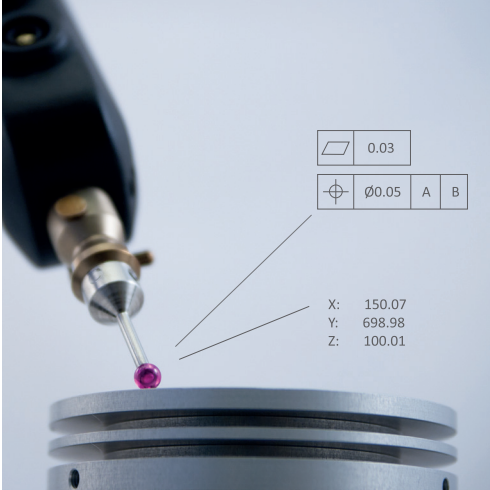

METRONOR TAKES CARE OF YOU

– AND YOUR INVESTMENT

- Metronor support – either direct or through our local partners – ensures timely attention to any issues and upgrades to keep your system current for years to come
- Modular design means your investment can grow with your business. With few exceptions, any Metronor system can be upgraded or re-configured to any other configuration
- No other company offers the same flexibility and long-term security that your investment will keep paying for itself whatever the future may bring

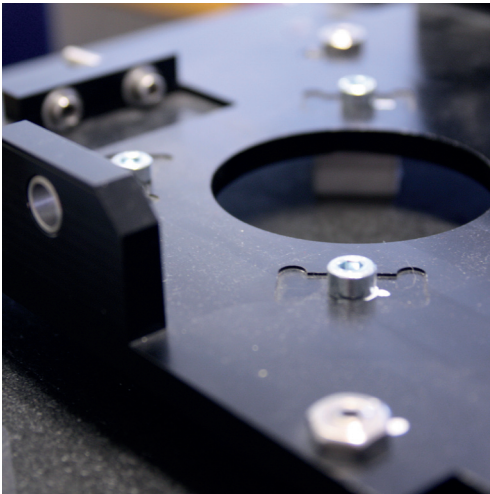



APPLICATIONS

FOR OUR SYSTEMS

DIMENSIONAL MANAGEMENT

Minimization of all sources of variability from tool - to part - to subassembly - to final assembly.

PART INSPECTION

The Metronor system's portability and vibration stability control enables direct measurement at the place of fabrication - no matter how harsh the environment - and does not require a dedicated inspection area.

SCANNING

Portable, large-volume, fast and sticker-free, our scanning systems scan fragile objects and surfaces and are ideal for in-process inspection, reverse engineering, tool and die inspection, on-machine inspection and as-built documentation.

PROTOTYPING

Metronor's versatile measurement systems provide invaluable data during prototyping to enable better functional designs. Whether automotive, aerospace or other industries, Metronor has the solution for fast and accurate capture of critical measurements and geometries.

PROTOTYPE SCANNING

For fast and easy scanning of clay models or completed prototypes, using Metronor TrackScan ensures that fragile surfaces remain unblemished and secures consistent and accurate data in large volumes.

AS BUILT DOCUMENTATION

Metronor portable CMMs with their large volume capacity and the unique probing capability enables to capture the exact geometry of most large objects - be it power generators, trucks, cars, aeroplanes or space satellites.

REPEATABILITY STUDIES

The Metronor DUO systems have the unique capability of measuring up to 48 points simultaneously, when coupled with an LED Kit.

ALIGNMENT

Metronor offers the fastest and most flexible way to precision assemble parts with continuous part position and orientation updates in all 6 degrees of freedom – thereby saving the cost of expensive assembly and mating tooling.

PIPING

Draw a virtual pipe in free space avoiding obstacles, creating a 3D CAD template, or just take measurements at the end points of an existing pipe and on the pipe itself and a CAD representation is created. Mirror flanges, overwrite measured angles manually, calculate values for springback correction, and so on.

JIGLESS ASSEMBLY

Metronor offers the fastest and most flexible way to precision assemble parts – saving the cost of expensive assembly and mating tooling.

EXCESS MATERIAL ANALYSIS

Metronor's unique "Excess Material Best-Fit" enables the CAD software to determine the optimal part balancing and alignment for machining becomes fast, efficient and guarantees enough material for a good part.

ASSEMBLY TOOL CERTIFICATION

To fully verify the performance of an assembly tool, it is necessary to verify the tool base condition for reproducibility of results, to verify the tool geometry to design CAD, to verify the repeatability of any moveable clamping devices and the overall ability of the tool to repeatedly position the parts. This is the job Metronor was originally designed for.

DEFORMATION ANALYSIS

With its ability to measure multiple points at the same instant, DUO along with the LED application kit is the ideal tool to measure deformation.

REVERSE ENGINEERING

With the Metronor system the basic geometries of even the most complex part with hidden features can be captured with ease.





INDUSTRIES

THAT BENEFIT FROM OUR SYSTEMS

AEROSPACE

Our systems are used for everything from inspecting large molds and castings, through to detail part inspection and is used with great success in moving line assembly.

AUTOMOTIVE

With the introduction of scanning to our systems, Metronor remain focused on the modern automotive production, honoring their very first system's legacy and giving customers the necessary competitive edge.

RAILWAY

Metronor portable CMM systems handle large volumes and efficiently and accurately inspect axles and bogies for flatness, squareness and straightness, as well as inspecting 'any' geometry to CAD design intent - ideally suited both for new production and maintenance work.

TRUCKS & BUSES

Metronor's SOLO system is perfectly suited for assembly and fabrication of large vehicles such as buses and trucks.

BOATS & YACHTS

Increasing demand for high quality and accuracy while keeping manufacturing costs down has led the boat and yacht industry to look to Metronor for portable CMM equipment, capable of handling large volume and demanding environment of modern yacht manufacturing.

FARM EQUIPMENT

Handling large volumes, aligning large parts like axles and bogies, inspecting parts for flatness and verifying geometries makes the Metronor system ideally suited for farm equipment manufacturers.

MOLD & DIE

Metronor enables comparing molds to CAD design data in minimum time as well as aligning molds, cores and inserts precisely to ensure quality product first time with minimum scrap and loss of time.

ENERGY

Metronor have a diversified range of customers in all branches of the energy industries: oil and gas exploration, wind energy, hydro-electric power plants, gas turbine production and nuclear power plants.

CASTING, FORGING & MACHINING

From aligning mold halves to verifying and optimizing excess material through to efficient alignment of cast parts for optimized machining with guaranteed coverage, Metronor systems offer the fastest and most cost-efficient process improvement tool available.

CONSTRUCTION EQUIPMENT AND EXCAVATORS

Large construction machines and equipment can be built faster and with better geometry control using Metronor's portable CMM.

METAL FABRICATION

From part inspection to jigless assembly and alignment of large parts, capturing geometry and as built data to recording fast alignment of parts on machine beds, the Metronor solutions are flexible and value-adding.

OTHER INDUSTRIES

The flexible and unique nature of the Metronor portable CMM family of products has allowed it to be adopted and adapted in many different industries.

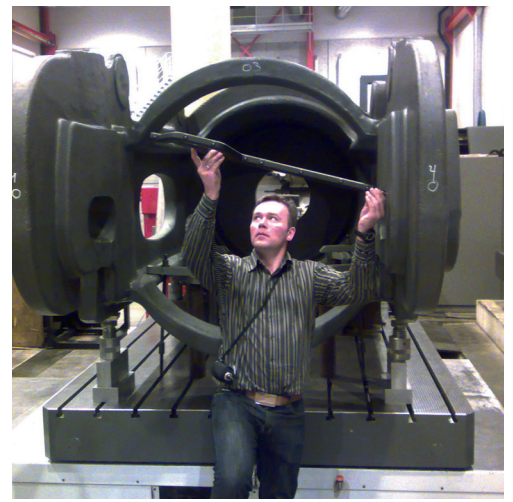



Metronor is a privately held ISO9001 certified high technology company headquartered outside Oslo, Norway. Metronor has developed a range of high accuracy, large volume, portable electro-optical coordinate measuring systems that provide excellent return on investment for our customers as well as facilitate a highly efficient dimensional management of their manufacturing processes.

Metronor Industrial Systems provides a range of measuring systems to a variety of industries worldwide, either through trusted partners or directly through offices in Norway, the US, Germany and Asia.

The flexible and robust nature of our systems enables them to be applied to a multitude of different applications within automotive, casting and machining, mold and die, energy and other transport and heavy industries. The systems are considered especially valuable when used for large measurement volumes, to optimize processes and in challenging environments.

More information at www.metronor.com



Scan the QR code
for information about
offices and partners contacts