

**3D-Coordinate Measuring Machine (CMM)
XOplus 55/77/98**

Technical Data



Technical Data XOplus 55/77/98

Short description

- CNC-bridge design measuring machine with touch-trigger or scanning probe systems
- All granite guide-ways are accurately hand-lapped
- Compact design operator workstation, with integrated controller and computer
- CMM available in multiple sizes for the optimal selection of the required measurement volume

Application areas

- In production, quality control, process and production control, in reverse engineering and model making
- Geometric and free-form components
- Both series and individual measurement
- Palletized operation possible

Standard features

- The Y-axis guide-way is machined directly into the base plate, providing optimal long-term stability
- Pre-stressed, encompassing air bearings in all axes
- Passive vibration dampers
- Active pneumatic vibration damping optionally available and field retrofittable
- Compact control panel with central, logarithmic joystick "mouse function" and context-sensitive function buttons
Selectable joystick axis assignment. Wireless version optionally available
- The X-and Y-guide-ways feature bellows protections against contamination
- High-speed-dynamic servo drives with position monitoring combined friction power transmission
- Three-axis contouring controller with intelligent "look-ahead" function for application-optimised trajectory
- Manual temperature compensation (Automatic temperature compensation on all axes and work piece optionally available)
- Two-stage speed selection and variable speed adjustment (override 0-100%) in all operation modes, resulting insensitive movement via joystick or in CNC mode

Probe systems

- PH10M/PH10T motorized indexing head
 - TP20 touch-trigger probe stylus module changeable via optional tool changer
 - TP200 touch-trigger probe, highly precise and suitable for styli up to 100mm in length. Styli can be changed via optional tool changer
- SP80 scanning probe head, highly precise for probe lengths up to 500mm. For scanning and single-point probing, stylus combinations can be changed via optional tool changer
- PH20™: Continuous 5-axis touch-trigger system with "head touch"
- PH10M motorized indexing head
 - SP25M scanning and single-point probe, precise and flexible for stylus lengths of up to 400mm. Probe module and stylus can be changed via optional tool changer
 - Shapetracer: 3D Line Scanner to report and handle point clouds
 - Phoenix II: Optical, non-contact 3D scanning probe, provide fast efficient metrology solution for feature recognition and surface analysis
- Manual probe system available (PH6, MH20i, etc)

Software

- User-friendly Windows based software for measuring and evaluating geometry and free-form elements (option)
- Graphic user interface featuring extensive automatism to support the user
- User dialog and reporting can be selected and switched on-line independently 15 languages
- Graphically interactive on-and offline programming system "Grips" for measurement program creation based on CAD data
- Numeric and graphic reporting of the measured results
- Workpiece-oriented database, SQL-capable, with multi-user access, network capabilities
- Integrated statistic functions, frequency distribution, trend diagram, machine-capability C_m and C_{mk}
- Shape-and location tolerances according to ISO 1101/ASME Y14.5M
- Context-sensitive online help in 15 user languages

Software options

- Software package for free-form surfaces
CAD direct interfaces (e.g. CATIA V4/V5, Pro-E, Unigraphics Parasolid)
- DMIS Import, DMIS Export, DMIS Reporting, DMIS Native Interpreter
- I+ +DME Server
- Blade analysis software package
- Export point and element data in VDA1 format
- SPC control charts, process capability c_x and c_{pk} , with the QS-STAT interface

Machine Type		XOplus 55			XOplus 77			XOplus 98			
Measurement Ranges, Weights											
Measurement ranges X	[mm]	500			700			900			
Y	[mm]	500	700	1000	1000	1500	2000	1200	1500	2000	
Z	[mm]	500			700			800			
Useable table surface	[mm]	750×1200	750×1400	750×1700	940×1780	940×2280	940×2780	1140×1980	1140×2280	1140×2780	
Machine weight	[kg]	980	1140	1260	2290	2560	3840	3230	3420	4970	
Permissible part weight	[kg]	200	300	300	800	800	1000	1500	1800	2000	
General Requirements											
Electric	Single-phase AC, 1P+N+PE, 115/230 V ± 10 %, 50/60 Hz, max. 1000 VA acc. to EN 60204/1										
Compressed air	Supply pressure 6-10 bar, pre-filtered, quality according to ISO 8573-1: Class 4 or better										
Air consumption	[^{Nl} /min]	Min. 70, higher consumption possible, depending on application (pneumatic dampers)									
Measuring Accuracy											
Measurement system	Photoelectric scale system, Optical division 20µm										
Resolution	[µm]	0.1									
–	–	TP200	SP25	TP200	SP25	TP200	SP25	TP200	SP25		
Probing uncertainty ¹	MPE _P [µm]	1.5	1.5	1.7	1.5	1.9	1.8				
Volumetric length measuring uncertainty ²	MPE _E [µm]	1.5+L/350	1.5+L/350	1.7+L/350	1.5+L/350	1.9+L/350	1.8+L/350				
Volumetric scanning probing uncertainty ³	MPE _{THP} [µm]	–	2.1	–	2.1	–	2.3				
Total measuring time for THP	MPT _{THP} [s]	–	68	–	68	–	68				
Operating Environment											
Operating temperature	[°C]	15 - 30									
Temperature range for MPE _E		18 - 22 °C, ΔT: 1 ^K / _h , 1 ^K / _m , 2 ^K / _d									
Relative humidity	[%]	40 - 70									
Dynamics											
Joystick-operation	v _{max} [^{mm} / _s]	0 - 20 (creep mode), 0 - 100 (normal)									
CNC-mode	v _{max} [^{mm} / _s]	300 axial, 520 volumetric									
CNC-mode	a _{max} [^{mm} / _s ²]	1200 axis-related 2000 volumetric				900 axis-related 1500 volumetric					

1: According to DIN EN ISO 10360-2 / Maximum Permissible Error MPE_P

- SP25M with Module SM25-1 and Styli Ø 4 x 21mm
- SP80 and Styli Ø 5x 50 mm
- TP200 with Standard Force Module and Styli Ø 4 x 21mm
- TP20 with Standard Force Module and Styli Ø 4 x 10mm

2: According to DIN EN ISO 10360-2 / Maximum Permissible Error MPE_E

- SP25M with Module SM25-1 and Styli Ø 4 x 21mm
- SP80 and Styli Ø 5x 50 mm
- TP200 with Standard Force Module and Styli Ø 4 x 21mm
- TP20 with Standard Force Module and Styli Ø 4 x 21mm

3: According to DIN EN ISO 10360-4 / Maximum Permissible Error MPE_{THP}

- SP25M with Module SM25-1 and Styli Ø 4 x 21mm
- SP80 and Styli Ø 5x 50 mm

We reserve the right to modify any design and specification without prior notice.

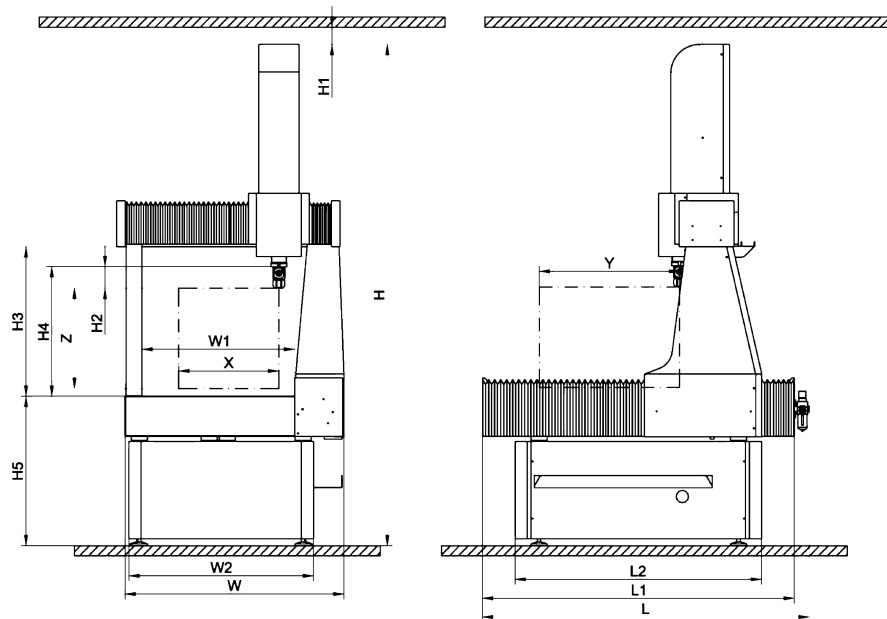

Dimensions [mm]									
	XOplus 55			XOplus 77			XOplus 98		
Mode (Y)	500	700	1000	1000	1500	2000	1200	1500	2000
H	2505			2935		2885	3135		3085
W	1135			1365			1575		
L	1390	1590	1920	2055	2640	3230	2255	2640	3230
X	500			700			900		
Y	500	700	1000	1000	1500	2000	1200	1500	2000
Z	500			700			800		
H1	50			50			50		
H2(PH10T)	80			80			80		
H3	745			925			1030		
H4	650			865			965		
H5	750			750	750	700	750	750	700
W1	765			945			1150		
W2	920			1109	1109	1200	1209	1209	1300
L1	1310	1510	1840	1975	2560	3150	2175	2560	3150
L2	980	1230	1530	1440	1940	2300	1640	1940	2300

Computer Trolley	
W	1200
L	900
H	750

Wenzel Measuring Machines(Shanghai) Co.Ltd
 No. 219, Song Xiu Road, Qingpu, Shanghai 201703
 Tel :+86 21 5970 3088
 Fax:+86 21 5970 3082
 info@wenzel-cmm.cn
 www.wenzel-cmm.cn